



**NO
MORE
DIGGING!**



SUREFOOT™
QUEENSLAND
CONCRETE FREE FOOTING SYSTEM
S.E. Queensland- Exclusive Distributors

INSTALLATION Manual

nomoredigging.com.au
1300 64 64 23

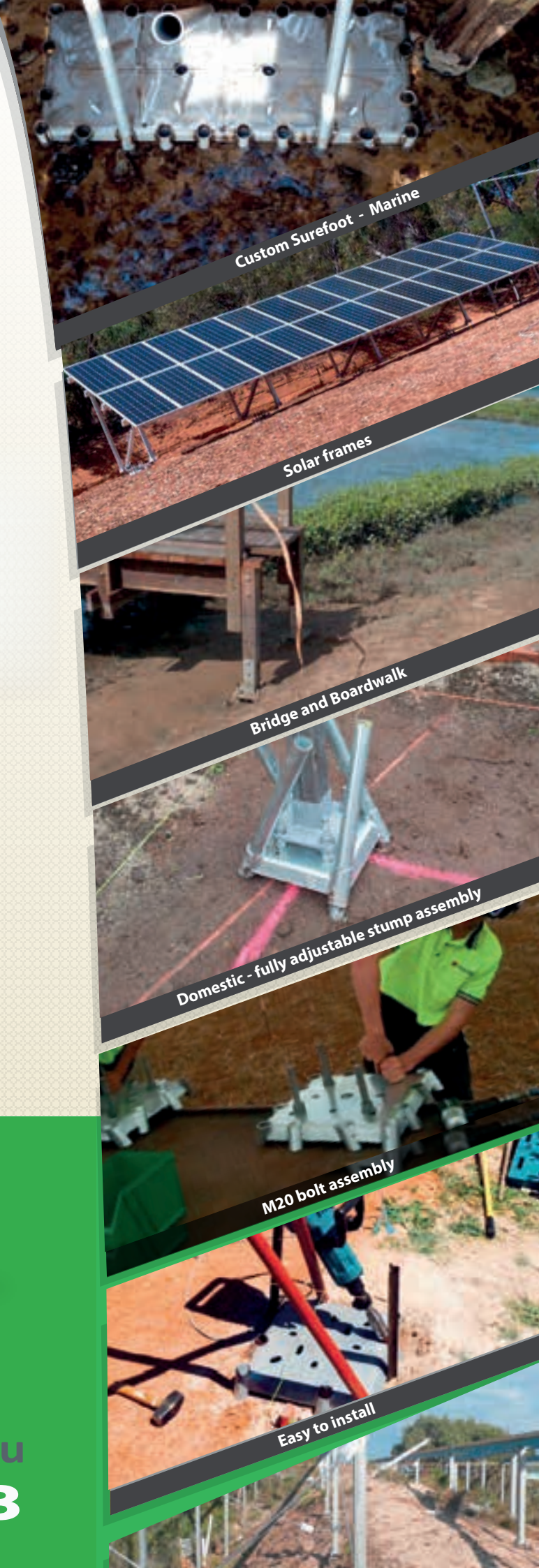

Custom Surefoot - Marine

Solar frames

Bridge and Boardwalk

Domestic - fully adjustable stump assembly

M20 bolt assembly

Easy to install

INSTALLATION Manual

Introduction	3
Installation Equipment/Tools	4
Installation Instructions	5
Trouble Shooting	6 - 7
Swaged Piles	8
Pile Record	10
Appendix A	
Pile record example	11
Appendix B	
Pile plan example	12
Appendix C	
Recommended Jack Hammers	14

Surefoot is an



View our installation
video on our Website



**“Surefoot is at the forefront of design,
innovative and environmentally
friendly footing systems”**

Engineering Principles

Surefoot engineering principles are based on piling technology using a combination of skin friction and bearing to achieve load capacities in various soil types.

Design capacity calculations are based on the working stress method, using refined geotechnical data, obtained throughout time for skin friction and bearing pressure.

Surefoot System

Surefoot is an “all in one system”, where the unique shape and high strength steel combines to create a very efficient pile cap. Once piles are driven and the cap secured, the opposing forces of the multi directional piles provides a solid, stable and economical footing. The system is designed to increase its efficiency when resisting gravity, uplift, shear and moment loads. Ultimately the soil structure absorbs the applied stress.

Our footing system is job specific and is designed according to site soil conditions, and structural design loads etc.

Pile Record

A pile record must be kept for each footing and once completed, returned to the consulting Engineer. Refer to Appendix A & B for the Pile Record document and plan example.

Adjustability

Depending upon the Surefoot type and design, the baseplate can be adjusted 100mm horizontally and 50mm vertically.

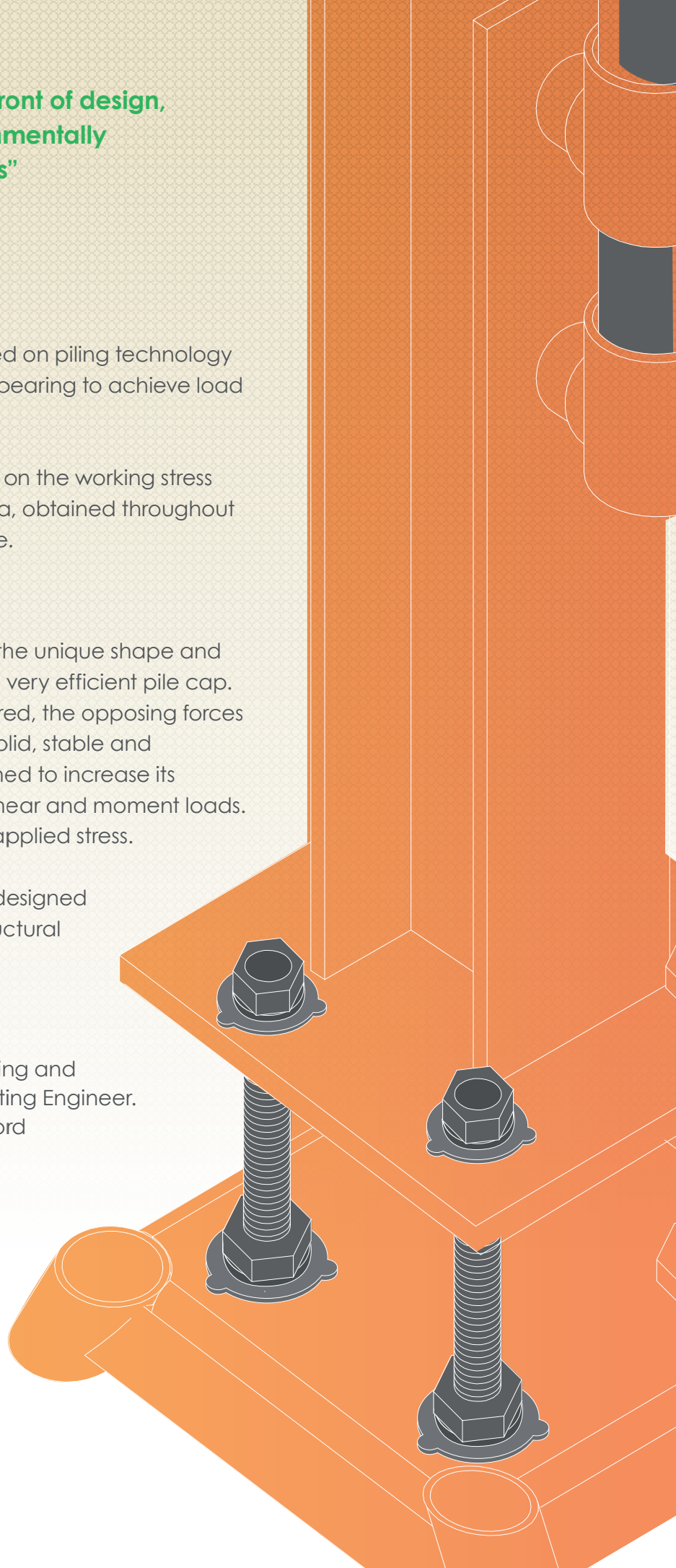

TOOLS REQUIRED

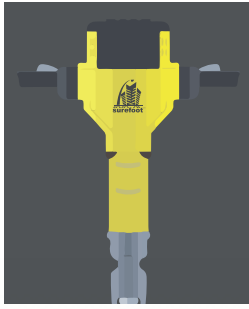

- Electric or petrol jackhammer for standard penetrable soils
- **45 Joules minimum impact energy**
- 30mm hex. - shaft

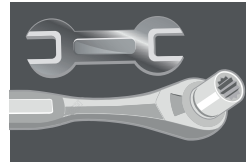

Socket Set

Bolt Type	Socket	
	Bolt	Nut
M20	30mm	32mm
M24	41mm	41mm



Sledge hammer



Jackhammer drivers to suit 30mm hex shaft.

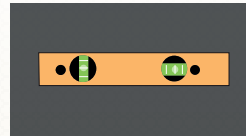

Small Level

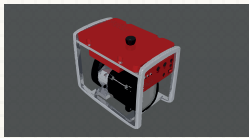

Generator / Power leads (if using electric tools)

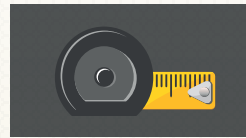

Tape measure



Cold gal. zinc rich touch up paint



Personal Protection Equipment

Safety footwear, heavy protection, eye protection (goggles) insulated protective gloves

High visibility shirt or vest



Grinder



Impact driver with 3/8" hex. bit for type 14 gauge Tek screw
5/16" hex. bit for series 500 Tek screw



"Piles are driven using simple hand held equipment"



INSTALLATION INSTRUCTIONS

Identify services

- 1 Mark and identify the location of any underground obstacles or services before driving the piles.

Pre - install hardware

- 2 Install all nuts and bolts and secure to Surefoot pile cap.

Set out

- 3 Set out and place the Surefoot pile cap in their correct position.

Bedding down

- 4 Protect the top surface of the surefoot with a timber block. Tap with a sledge hammer to bed down and level into the soil.

Load and semi - drive piles

- 5 Slide apposing piles through the guide tubes in the Surefoot.

Level and secure the plate

- 6 Using a small sledge hammer drive the piles 200-300mm to secure the plate. Do the same with the rest of the piles in the Surefoot.

Drive the piles

- 7 Then drive each pile alternately in increments with the jackhammer, periodically checking for level. Drive to designed pile embedment depth or refusal, see notes Pg. 06.

Complete driving piles

- 8 Finish driving piles with the jackhammer until piles are flush with Surefoot plate.

Lock the plate in place

- 9 Using the jackhammer through the center hole in the Surefoot, drive down the plate until the piles are tightly locked in.

Finishing the plate

- 10 If refusal conditions are met and the Engineer has approved the cut piles, note in the pile log and paint exposed metal with cold gal Zinc rich touch up paint.

Install Tek screws

- 11 Install the self drilling Tek screws through the Surefoot sleeves using a low speed and high torque, securing the pile to the Surefoot pile cap.

Pile record

- 12 A pile record must be kept for each footing and returned to the Engineer once completed, refer



Welding directly to Surefoot



Assembly of nuts and bolts

TROUBLE SHOOTING

Services

Before you start the installation, identify all underground services. If you suspect the driven pile may interfere:

- A-** Rotate the Surefoot to redirect the pile.
- B-** Upgrade the Surefoot size to allow for more pile placement options. As long as the Engineer is aware of underground obstacles or utilities, a custom design Surefoot can be made to keep the piles from this area. We have 2, 3 and 4 way Surefoot pile options. 2 and 3 way Surefoot could be used to avoid an obstruction.

Obstruction

- A-** If a pile stops moving when driven in - STOP driving the pile!
- B-** Be sure that the other piles are at least half way in to stabilise the Surefoot plate.
- C-** Give the obstructed pile one or two firm hits with the sledge hammer. If the pile bounces it could be either a pipe or tree root. If the pile feels solid, it could be an isolated rock (*refer to Rock Policy*). Address these issues as suggested:
 - C.1** Service Pipe - Remove Surefoot plate, reposition / change pile direction to avoid the obstruction.
 - C.2** Tree root - Small Tree: Cut the pile end at 45° and jackhammer pile through the tree root.
Large Tree: As per C.1

Diagram Showing Obstruction



Services / Tree / Rock

2 ways / 3 Ways

2 and 3 way Surefoot
could be used to avoid
an obstruction

Obstruction



Extra Adjustment



Customised

Rock policy

1. Our general policy is that the designed embedment depth of piles must be achieved or to the "point of refusal", whichever is the lesser. Avoid using Surefoot in "harder" igneous or metamorphic rock such as solid granite or bluestone.

2. The test for "refusal", is where the pile penetration for each 15 seconds of hammer time is less than 5 mm. This is based upon a minimum Jack hammer rating of 45 Joules.

3. The minimum embedment depth of the pile is generally 700 mm. Some softer rock or "floaters" may be fractured by increasing the the capacity of the pneumatic hammer. Our micropile tends to "core" into softer rocks with sustained pressure. The minimum penetration into the rock is 100 to 200 mm. Pre drilling of pilot holes may be required to achieve the designed or minimum depth.

4. Alternatively, consider whether the Surefoot footing could be slightly repositioned to avoid the rock. Also consider using a greater sized cap, which gives greater pile location options.

5. Where rock is encountered very close to the surface and the minimum embedment depth cannot be achieved, please consult with the certifying Engineer or trained Surefoot staff for instructions. Provide a pile record and plan to the Engineer for reference. This should indicate the pile location and driven pile depths. Photos may be useful, if available.

Keeping the Surefoot in position

To keep Surefoot in the correct location you may use the centre sleeve in the Surefoot pile cap and partially drive a micropile off cut down to prevent movement. This is recommended on sloping sites

Driving the pile to specified depth

If is there a problem driving the micropile to the specified depth the certifying Engineer or Surefoot should be contacted to provide further instruction.

Levelling and relocation the pile cap

Surefoot should be installed level. Only Surefoot combined with a bolt and baseplate assembly is adjustable for level. Follow points 4 to 7 of the installation instructions.

If your Surefoot pile cap is distinctly out of level in the early stages we recommend that you start again.



To remove the pile cap, the micropile should be cut off beneath the pile cap sleeve in order to rotate or relocate the footing

SWAGED PILES

These piles are "joined" piles and are used where access for driving piles is limited and eliminates single long pile lengths.

1. Driven piles result in flared edges which require cutting off. Using an external driver attachment, drive the standard pile end through the Surefoot guide to within 100 mm of the plate.
2. Drive down and cut the flared edge off the narrow swaged pile end. (Approx. 30 – 50 mm)
3. Place the second standard pile onto the cut swaged end and hammer down so that the joined piles pass through the Surefoot guide. Continue driving the swaged pile to the recommended pile embedment depth.

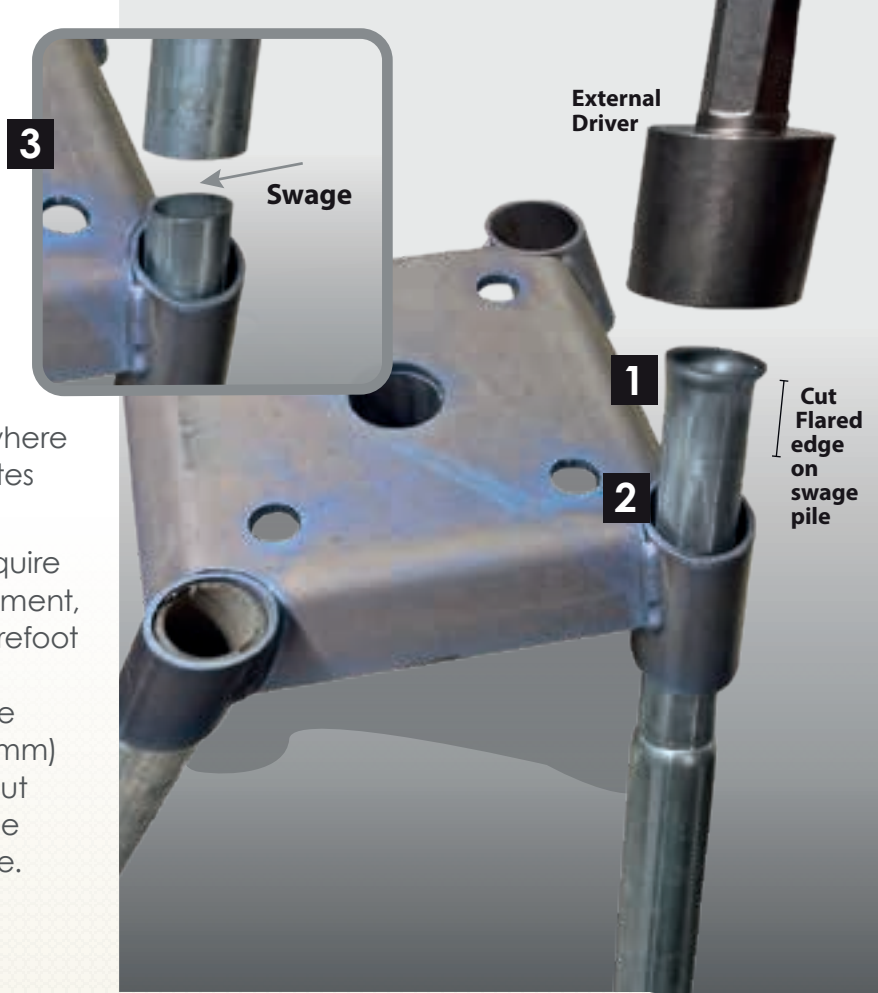

DON'T FORGET TO WORK SAFE!



Let the machine do the work



Correct Use of Jackhammer

Falling Hazard

DO NOT LEAN ON THE JACK HAMMER AS IT PLACES STRESS ON THE DRIVER RESULTING IN BREAKAGE



Incorrect Use of Jackhammer



Shade Sail



Directional Surefoot

LONG PILES

To start off long piles in any soil use a hand held "Star Picket" driver or a petrol driven overhead driver".





Clients Name:

Job Address:

Date:

Specified Pile Embedment Depth:

Footing #	Pile#	Embedment	Comment

Pile Record Note: 1- Print Clearly in Pen If returning this pile record to the certifying Engineer, provide a plan and identify the Footing Number

Comments

Installation Supervisor

Signature

Date

PILE RECORD



Job

Date

Specified Depth

Footing #	Pile #	Embedment	Comment
eg.			
1	1	1450	O.K
	2	1450	O.K
	3	1450	O.K
	4	900	Refusal on solid rock
	5	1450	Extra centre pile added due to Engineer's request to compensate for "soft spot"
2	1	1450	O.K
	2	1450	O.K
	3	1450	O.K
	4	1450	O.K
3	1	600	Refusal <700mm contact Engineer
	2	900	O.K refusal Engineering approved
	3	1000	O.K refusal Piles 1, 2 & 3
	4	1450	O.K
4	1	1450	O.K
	2	1450	O.K
	3	1450	O.K
	4	1450	O.K

Pile Record Note:

1- Print Clearly in Pen

2 - If returning this pile record to the certifying Engineer, provide a plan and identify the Footing Number

Comments Discussion with certifying engineer, directed to use an extra pile to compensate for the soft spot.

Installation Supervisor Name

Signature Signature

Date Date

PILE RECORD PLAN EXAMPLE

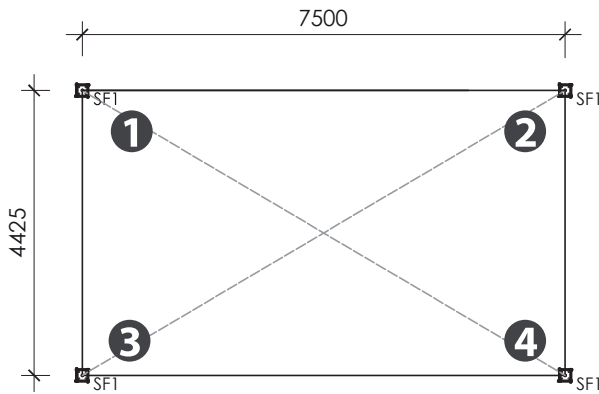

← Example of Pile Record Plan, identifying and showing location of the SUREFOOT

SUREFOOT PLAN LAYOUT
NTS

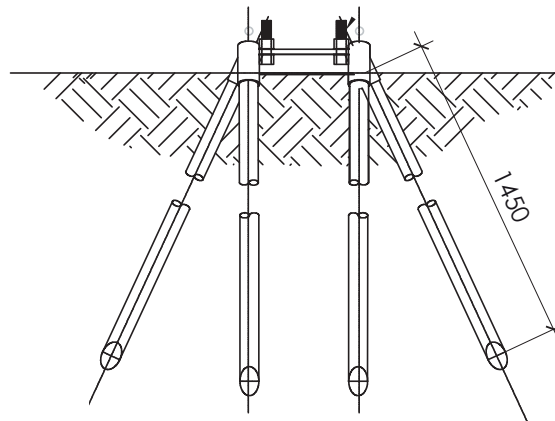

TYPICAL SECTION- S250
NTS

				 NO MORE DIGGING! nomoredigging.com.au	CLIENT:		
NO.	DATE	BY	DESCRIPTION				
REVISIONS							
PROJECT:				TITLE:			
-----				SUREFOOT LOCATION			
SITE ADDRESS:				RBP CERTIFICATION: ----		DRAWING NO.	REV.
-----				DESIGNED: CP	SCALE: AS SHOWN	STR-001	A
				DRAWN: AE	JOB NO: ----		
				CHECKED: CP	DATE: ----		



S250 with fully adjustable stump assembly - Domestic Project



S400 Stainless Steel Surefoot - Marine Environment



Mining



Marine Environment Commercial



S250 Installation

Examples of equipment used to drive Surepiles

SELECT A JACKHAMMER RATED AT A MINIMUM 45 JOULES TO COMPLETE DRIVING PILES TO SPECIFICATION

Type	Image	Brand	Model	Rating	Notes
Petrol Overhead Driver		Various		26 Joules	STARTING LONGER PILES 1.93 - 2.4 m Lightweight overhead petrol driven star picket driver used for starting long piles in softer soils. Weighs approximately 13- 15kg
Electrical Jackhammer		Various		45 Joules Minimum	STANDARD INSTALLATION in softer clays and sand - Electrical Jackhammer rated at a minimum 45 joules. This is a prerequisite in order to comply with our test for "refusal"- refer to page
Petrol Jackhammer		Various		45 Joules Minimum	STANDARD INSTALLATION in softer clays and sand - Petrol Jackhammer rated at a minimum 45 joules. This is a prerequisite in order to comply with our test for " refusal "- refer to page 7. Weight 18.5kg - 21 kg , 30mm hexagonal shaft
Electrical Heavy Duty Breaker		Hilti	TE 3000-AVR	68 Joules	FINISHING PILES (OPTIONAL) in very hard clays or soft rock - Hard hitting jackhammer weighing approximately 30 kg, specialised driver bit required- check with Surefoot
Hydraulic Power Pack & Post/pile Driver		Various		68 Joules+	FINISHING PILES (OPTIONAL) in very hard clays or soft rock - Hydraulic power pack and post / pile driver attachment

NOTES



INSTALLATION

M a n u a l



No More Digging Pty Ltd T/a SUREFOOT QUEENSLAND
S.E. Queensland - Exclusive Distributors

1300 64 64 23

nomoredigging.com.au

